

Datasheet



CACHÉ® HONEYCOMB® Aerator JR Size Male M21.5×1

flow, stop and go®



Materials used

Body: POM
O-Rings: EPDM (black)
Silicone (blue)

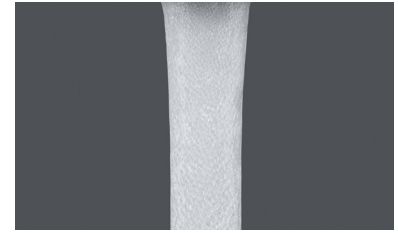

Aerated stream

Model Overview

Restricted flow rates	Color Code	Part. No.	Wetted surface area (in mm ²)
Z (7.5-9.0 l/min @ 3 bar)	light green	42.2202.010	4198
A (13.5-15.0 l/min @ 3 bar)	light blue	42.2203.010	4268
B (22.8-25.2 l/min @ 3 bar)	dark blue	42.2205.010	4283
X (2.2 gpm max @ 60 psi)	red	42.2201.010	4205
Q optimal performance & aeration: 0.1-0.6 bar	green	light grey ring 42.2275.010	4274
V optimal performance & aeration: 0.2-1 bar	blue	white ring 42.3230.010	4714

Imperial flow rates	Color Code	Part. No.	Wetted surface area (in mm ²)
PCA® 0.5 gpm max.	lime green	42.2259.010	4933
PCA® 1.0 gpm max.	dark blue	42.2258.010	4933
PCA® 1.2 gpm max.	pink	42.2260.010	4933
PCA® 1.5 gpm max.	green	42.2256.010	4933
PCA® 1.75 gpm max.	light blue	42.2261.010	4933
PCA® 2.0 gpm max.	lilac	42.2257.010	4933
PCA® 2.2 gpm max.	yellow	42.2253.010	4933

Metric flow rates	Color code	Part. No.	Wetted surface area (in mm ²)
PCA® 5.0 l/min.	orange	42.2251.010	4933
PCA® 7.0 l/min.	light green	42.2255.010	4933
PCA® 8.0 l/min.	white	42.2254.010	4933

Application Areas

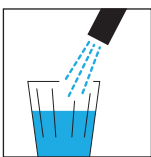

Drinking water only

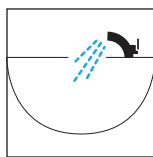

Basin faucet

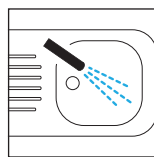

Kitchen faucet

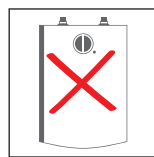

Not suitable for pressureless water heaters

Assembly Instructions

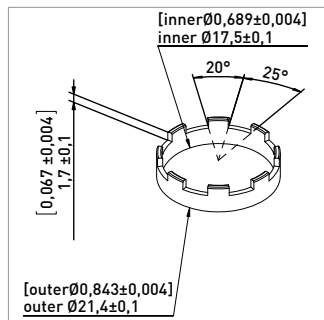
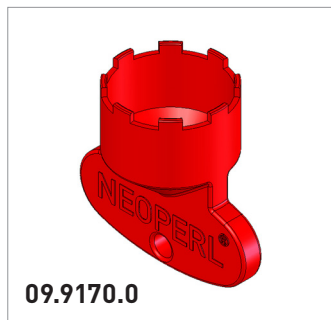
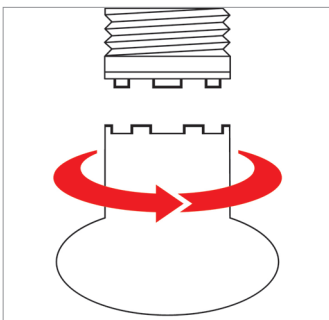

ATTENTION!

Max. mounting torque **0.5 Nm**
Do not use silicone oil/grease

Dimensions (in mm)

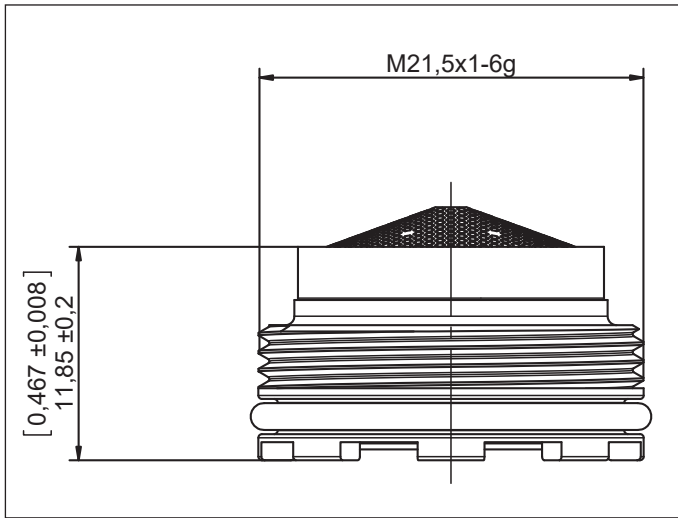

CACHÉ® HC JR M21.5x1

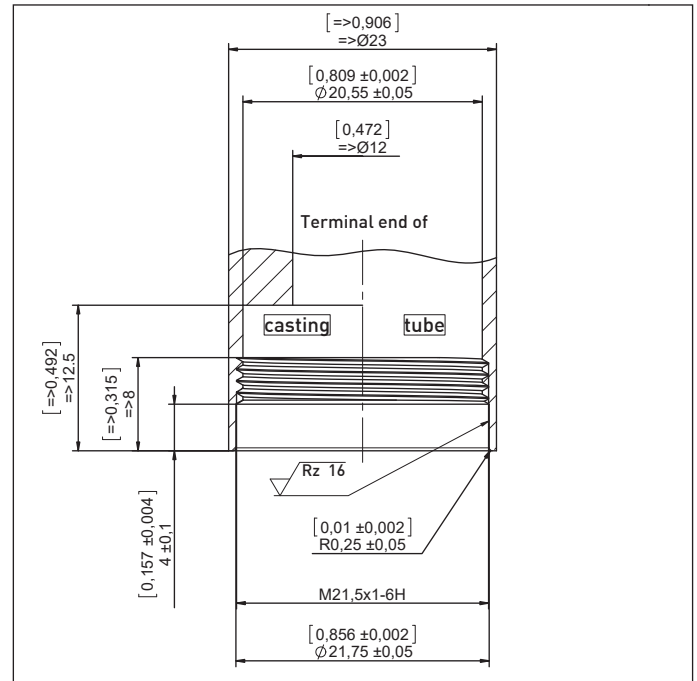

Recommended Mounting Dimensions

For pressure resistance reasons,
thread must be true to gage!
Screw aerator in until flush with spout end.

ATTENTION!

Product may not be altered!
Shall be used for hot water application exceeding 70°C

Operating Conditions

Continuous

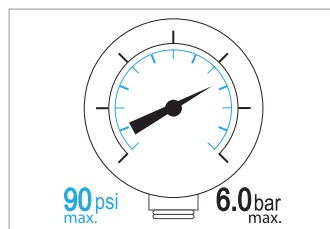
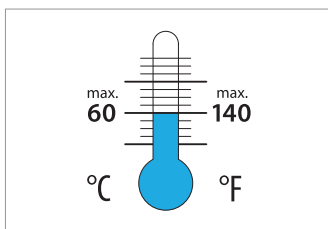

Short-term (3 minutes max.)

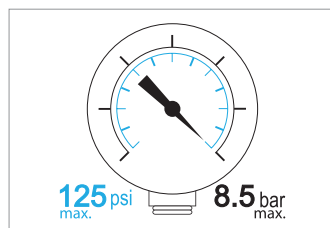
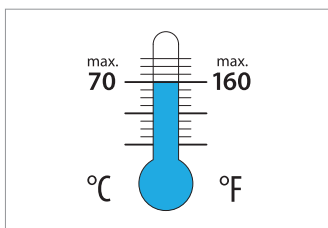

Indicated pressure values refer to supply line pressure.
Avoid water hammer.

Trademarks are registered in various countries