

# Datasheet



flow, stop and go®

## PERLATOR® Coin Slot Aerators STD Size Male M24x1



Flow classes Z-C: long sleeve  
PCA® flow rates, V: short sleeve

### Materials used

Body: POM  
O-Ring: EPDM  
(only PCA® models)  
Washer: EPDM



Aerated stream

Threaded metal-free aerator with integrated coin slot for easy installation/removal: no need for special key. Suitable to replace any classical aerator with male M24x1 housing.

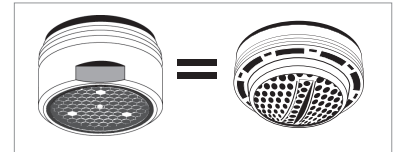

100% compatible with M24x1

## Model Overview

### PERLATOR® Coin Slot Aerators

Flow class	Color code	Part. No.	Wetted surface area (in mm <sup>2</sup> )
Z (7.5-9.0 l/min at 3 bar)	light green	45.2002.000	4716
A (13.5-15.0 l/min at 3 bar)	light blue	45.2003.000	4806
B (22.8-25.2 l/min at 3 bar)	light grey	45.2005.000	4840
C (27.0-30.0 l/min at 3 bar)	dark grey	45.2006.000	4823
V (optimal performance and aeration from 0.2-1 bar)	blue	45.3030.000	4033
<b>Metric flow rates (@3 bar / 20°C)</b>			
PCA® 5.0 l/min	orange	45.2051.000	4596
PCA® 7.0 l/min	light green	45.2055.000	4596
PCA® 8.0 l/min	white	45.2054.000	4596
<b>Imperial flow rates (@60psi / 38°C)</b>			
PCA® 1.0 gpm max.	blue	45.2058.000	4537
PCA® 1.2 gpm max.	pink	45.2060.000	4537
PCA® 1.5 gpm max.	green	45.2056.000	4596
PCA® 1.75 gpm max.	light blue	45.2061.000	4596
PCA® 2.0 gpm max.	lilac	45.2057.000	4533
PCA® 2.2 gpm max.	yellow	45.2053.000	4596

## Assembly Instructions

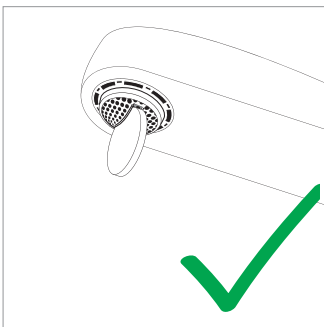

**Only use suitable coin.**  
**Do not use other tools.**

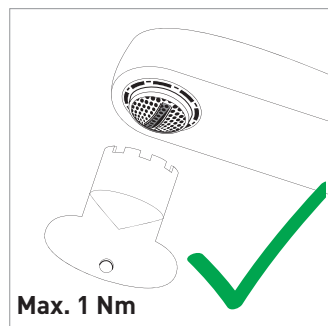

Max. 1 Nm

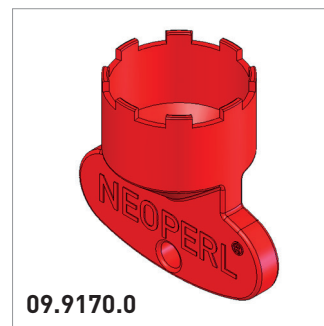

09.9170.0

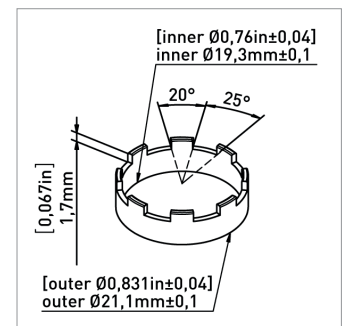

Use NEOPERL key 09.9170.0 or refer to above dimensions for self-made assembly tools.

# Datasheet



## PERLATOR® Coin Slot Aerators STD Size Male M24x1

flow, stop and go®

### Dimensions (in mm) according to EN246

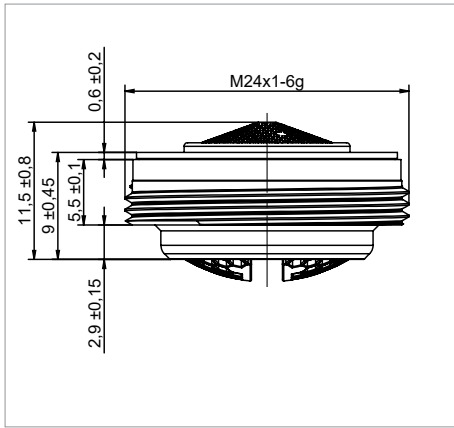

PL-CS-PCA®-STD with short sleeve

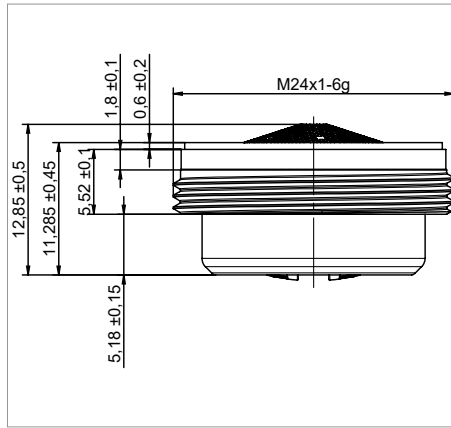

PL-CS-PCA®-STD with long sleeve

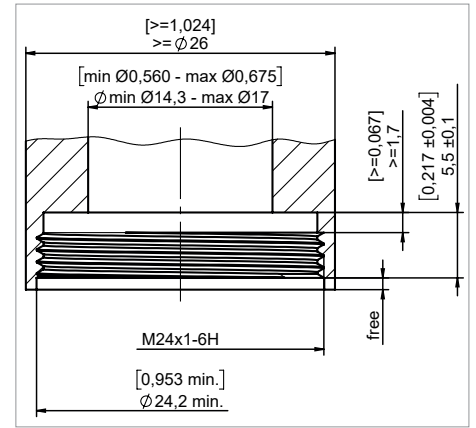

Recommended Mounting Dimensions

**For pressure resistance reasons, thread must be true to gage! Screw aerator in until flush with spout end.**

PERLATOR Coin Slot M24x1 faucet aerators are fully compatible with the mounting and pressure requirements of the European Standard EN 246.

### Application Areas



Drinking water only

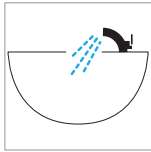

Basin faucet

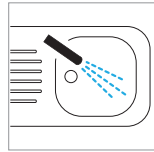

Kitchen faucet

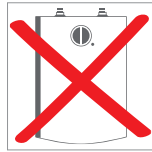

Not suitable for pressureless water heaters

### Operating Conditions

#### Continuous

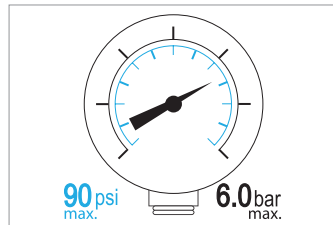
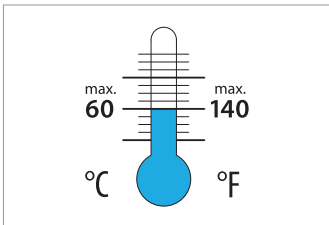

#### ATTENTION!

Product may not be altered!

Shall be used for hot water application exceeding 70°C

#### Short-term (3 minutes max.)

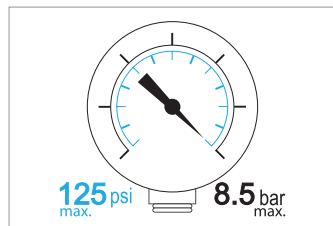
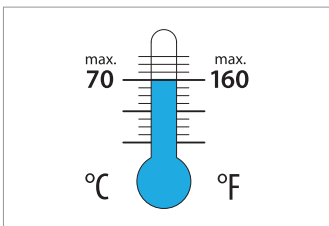

Indicated pressure values refer to supply line pressure. Avoid water hammer.